



FOOD EQUIPMENT CATALOG

(Revised 2023)

TABLE OF CONTENTS

Seelye PN	Description	Page #
100-013SC	Fry Dump stand w/ Ceramic Food Warmer - 27"	1
100-014SC	Fry Dumpstand w/ Ceramic Food Warmer – 27” (CSA approved for Canada)	1
100-036	Fry Dump stand w/ Ceramic Food Warmer - 36"	1
10021763#1	Replacement Ceramic Warmer for 27" Dump stand	2
10021764#2	Replacement Ceramic Warmer for 36" Dump stand	2
132-013	Drop in Sink	25
132-017	Paper Collar Holder	22
140-005	Universal Baffle for MLCONED-001 & MSCONED-001	4
140-007	Springs for MLCONED-001 & MSCONED-001	4
141-302SC	Add on Cup Dispenser	26
141-306	Three Hole Cone Drawer	27
141-307	Four Hole Cone Drawer	27
1HCH	One Hole Cone Holder	14
1PCH-01	1 Prong Paper Collar Holder	23
201-123	Replacement Warmer for 27" Hatco Glo-Ray	2
201124	Replacement mounting brackets for Hatco Warmer 201-123	2
205	Fudge Pump Stand 2.5" tall	15
290797	9" Stand Off Brace for 4 bank Dispenser	18
290798	9" Stand Off Brace for 2 bank Dispenser	18
3HC-001	3 Hole Cover	19
460-009	Drink Lid Holder	20
49-2	Drawer Latch for MLCONED-001 & MSCONED-001	4
4PCH-O1	4 Prong Paper Collar Holder	24
500	5" Tall Fudge Pump Stand	15
5HCH	Five Hole Cone Holder	14
CC22G-001	Cake Comb	12
DBM-3ROUND	3" round Dilly Bar Mold	13
DLFFDS6	Replacement divider for Fry Dumpstand	2
DLFFDS5	Replacement perforated tray for Fry Dumpstand	2
DLFFDSSCOOP	Replacement fry scoop for Fry Dumpstand	2
FC1043	8" Round	12
FC1044	10" Round	12
FC1045	Rectangular	12
FC1046	Large Heart Shaped	12
FC1242	2" Tall Small Heart Shaped	12
FC2006	6" Round x 2" height	12
FP0042	Small Fry Scoop	3
FP0093	4oz Fry Scoop	3
LRCF-002	Log Roll Cake Form	12
	Modular Cup/Cone Dispenser information sheet –includes spare parts	4
MCCAB-001	Assembled Modular Cup/Cone Dispenser	5
MCCAB-004	Assembled Modular Cup/Cone Dispenser	5
MCCABBLAIDQ	Assembled Modular Cup/Cone Dispenser	6
MCCABTLAIDQ	Assembled Modular Cup/Cone Dispenser	6
MCUPD-001	Modular Cup Dispenser	7
MCUPDB-001	Cup Dispenser Back	7
MLCONED-001	Modular Large Cone Dispenser	8
MMB16-001	Modular Mounting Bracket 16"	9
MMB26-001P	Modular Mounting Bracket 26"	9
MSCONED-001	Modular Small Cone Dispenser	8
MSMB-001L	Modular Side Mount Bracket	10
MSMB-001R	Modular Side Mount Bracket	10
PHT-001	Printer Holding Tray	11
PPHC-001	Parchment Paper Holder - Complete w/ Mtg. Brkt	21
SJR-004	Server Jar Rack	16
SJR-006	Server Jar Rack	17
SJR-006-2X2	Server Jar Rack	17
SJR-006-4W	Server Jar Rack	17
XT3120250A	Fir tree rivets	4

Fry Dump Stand

100-013SC

27" wide w/ ceramic warmer

100-014SC

27" wide with ceramic warmer *(CSA approved for use in Canada.)*

100-036

36" wide with ceramic warmer

The 100-013SC, 100-014SC & 100-036 fry dump stands use a Hatco ceramic warmer. The warmers can be removed for easy cleaning of the dump stand body. All units feature 2 drip pans, 2 perforated trays and 2 adjustable dividers for easy cleaning in most standard dish washers. The overhead storage area is perfect for bags and fry boxes.



Included

Dump Stand
Food warmer
(2) drip trays, (2) dividers, (2) perforated trays,
(1) fry scoop holder
Hardware
Spare parts
See next page

Warranty

One-year parts and workmanship, excluding labor.

Hatco warmers; 18-month warranty from manufacture date

Dimensions

22.75" high x 25.5" deep x either 27" or 36" wide

Specification/Installation:

120/1/6 – 110 watts, w/ cord, and plug, 9.2 amps

Shipping weight

27" wide models – 80 lbs

36" wide models – 95 lbs

Fry Dump Stand spare parts

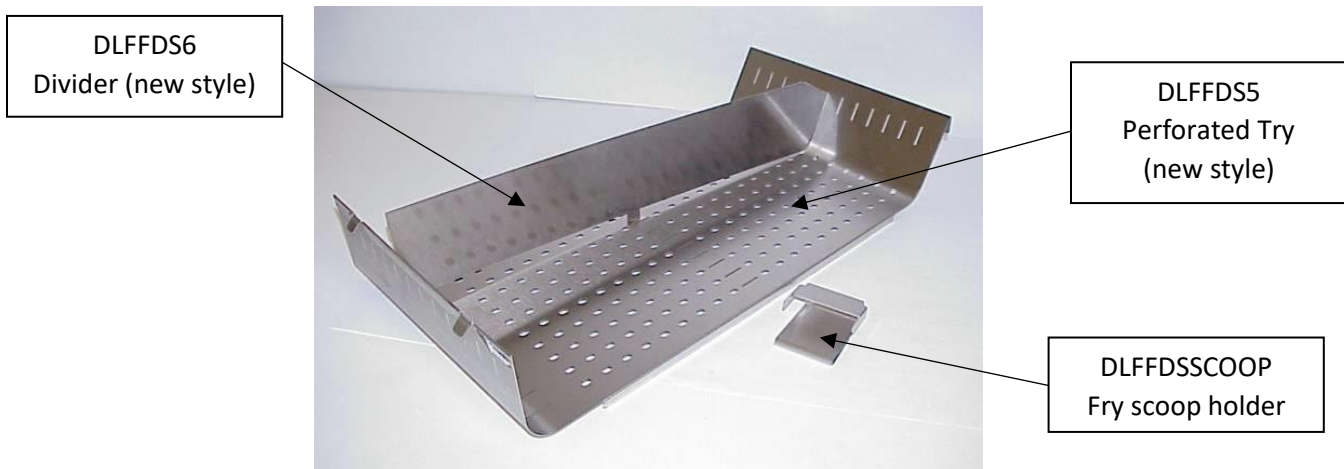

DLFFDS6 – A divider that sits in the perforated trays. The “new style” divider is shown above. An old style may be requested – those dividers have pins to mount to the perforated tray.

DLFFDS5 – The “new style” tray is 13.5” wide and now has slots for the divider, where the “old style” tray was 27” wide. Quantity 2 trays are required.

DLFFDSSCOOP – this is the holder for the fry scoop. The fry scoops are not provided by Seelye and do not come with a Fry Dump Stand.

201124 – Mounting brackets for Hatco warmer 201-123 – see mounting bracket instruction page for more details.

Food warmer replacement part numbers

100-012SC Fry Dump uses food warmer **part number 201-123**

100-013SC Fry Dump uses food warmer **part number 10021763#1**

100-014SC Fry Dump uses food warmer **part number 10021763#2**

100-036 Fry Dump uses food warmer **part number 10021764#2**

Hatco parts & Service – 1-800-558-0607

**For any warranty issues, please contact Hatco with the serial number located on the back of the warmer.*

Fry Scoops

FP0042

Medium Fry Scoop

FP0093

Small Fry Scoop

The Fry Scoops are designed to scoop fries in desired portions. Small fry scoop will scoop amount necessary for a small fry box, and the medium fry scoop will scoop amount necessary for a medium fry box.



Warranty

One-year parts and workmanship, excluding labor.

Dimensions

FP0042 - 3.35" x 2.014" at base, 2.5" tall.

FP0093 - 2.95" x 2.014" at base, 2.164" tall.

Material

304 Stainless Steel

Included

Fry Scoop

Shipping weight

Approx. 1 lb.

MODULAR CUP/CONE DISPENSER INFORMATION SHEET

The Seelye Craftsmen Co. Modular cup cone system consists of universal cup dispensing units and large and small size cone dispensing units with mounting brackets to fit almost any freezer width. Any combination of cup or cone dispensers may be used. All sides of each dispenser have mounting holes to attach to another dispenser.

Basic components of the modular system

MCUPD-001 – universal cup dispenser. (cups up to 4.75" dia.).

MLCONED-001 – For large and medium cone dispensing.

MSCONED-001 – For small size cone dispensing.

MMB16-001 – For mounting a modular system on freezers 13-1/4" to 19-1/2" width.

MMB20-001P - For mounting a modular system on freezers 17-1/2" to 23-1/2" width.

MMB26-001P - For mounting a modular system on freezers 23-1/4" to 29-1/2" width.

MMSB-001R – For side mounting when you cannot have any on top of the unit. (right side version).

MMSB-001L – For side mounting when you cannot have any on top of the unit. (left side version).

Common spare parts

140-005 – baffle (fits both MLCONED-001 & MS-CONED-001)

49-2 – turn latch

140-007 – springs

MCUPDB-001 – cup dispenser back

XT3120250A – Fir tree rivets

Full assemblies for 26" wide freezers are available under the following part numbers

MCCAB-001 – 3 vertical rows – top row 6 cup dispensers, middle row 5 cup dispensers, bottom row 2 cup dispensers, 2 large cone dispensers and 1 small cone dispensers.

MCCAB-004 – 2 vertical rows – top row 7 cup dispensers, bottom row 4 cup dispensers, 2 large cone dispensers and 1 small cone dispensers.

MCCABLAIDQ – 1 vertical row of 5 cup dispensers

MCCABTLAIDQ – 1 vertical row of 6 cup dispensers with 1 small cone dispenser and 2 large cone dispensers horizontally

The first thing you should ask the customers is how wide their freezer is.

Modular Cup/Cone Assemblies

MCCAB-001



This assembly unit comes with 13 Cup Dispensers (MCUPD-001), 2 Large Cone Dispensers (MLCONED-001), 1 Small Cone Dispenser (MSCONED-001) and 1 Modular Mounting Bracket (MMB26-001).

Warranty

One year parts and workmanship, excluding labor.

Dimensions

Assembled dimensions with mounting bracket: 31.5" wide x 28.6" deep x 25" tall

Included

MCCAB-001

Extra mounting hardware

Springs for use on cup dispensers.

Shipping details

Unit ships crated: Crate size 48" x 42" x 31"

Approx. 230lbs.

MCCAB-004

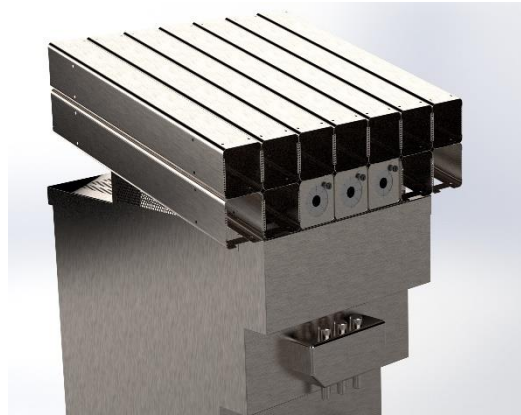

This assembly unit comes with 11 Cup Dispensers (MCUPD-001), 2 Large Cone Dispensers (MLCONED-001), 1 Small Cone Dispenser (MSCONED-001) and 1 Modular Mounting Bracket (MMB26-001).

Warranty

One year parts and workmanship, excluding labor.

Dimensions

Assembled dimensions with mounting bracket: 37" wide x 28.6" deep x 19" tall

Included

MCCAB-004

Extra mounting hardware

Springs for use on cup dispensers.

Shipping details

Unit ships crated: Crate size 48" x 40" x 26"

Approx. 210lbs.

Modular Cup/Cone Assemblies

MCCABBLAIDQ



This assembly unit comes with 5 cup dispensers (MCUPD-001) and 1 Modular Mounting Bracket (MMB26-001).

Warranty

One-year parts and workmanship, excluding labor.

Included

MCCABBLAIDQ
Extra mounting hardware
Springs for use on cup dispensers

Shipping details

Unit ships crated: Crate size 48" x 42" x 24"
Approx. 100 lbs

MCCABTLAIDQ

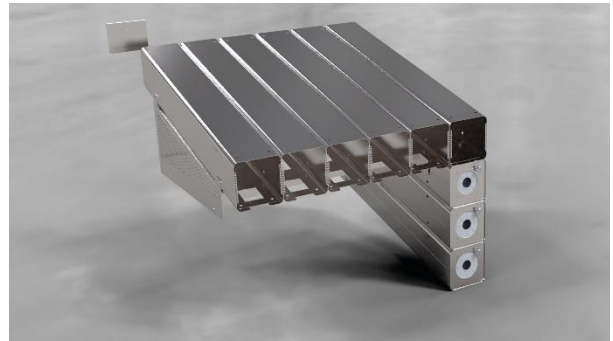

This assembly unit comes with 6 cup dispensers (MCUPD-001), 2 Large Cone Dispensers (MLCONED-001), 1 Small Cone Dispenser (MSCONED-001) and 1 Modular Mounting Bracket (MMB26-001).

Warranty

One-year parts and workmanship, excluding labor.

Included

MCCABTLAIDQ
Extra mounting hardware
Springs for use on cup dispensers

Shipping details

Unit ships crated: Crate size 48" x 42" x 24"
Approx. 100 lbs

Modular Cup Dispenser

The Modular Cup Dispenser is a universal design that can dispense several different items; any size paper cup, clear cup, sundae dish, parfait dish and the universal dome lid. This dispenser can be attached to other Cup Dispensers or Cone Dispensers (MLCONED-001/MSCONED-001). This unit now comes with a back plate to prevent cups from falling out the back of the dispenser.

MCUPD-001

Modular Cup Dispenser

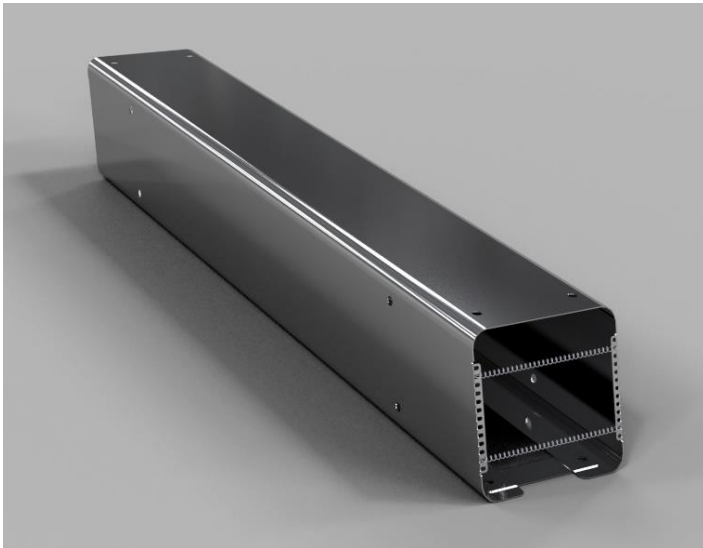

MCUPDB-001

Modular Cup Dispenser Back

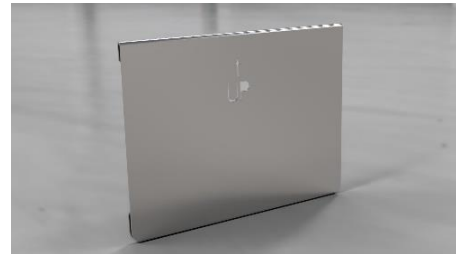

Included

Modular Cup Dispenser
Modular Cup Dispenser Back
Hardware to attach to another Modular cup or cone unit.

Set of 3 springs

Spare Parts

Springs
P/N 140-007
Modular Cup Dispenser Back
P/N MCUPDB-001

Warranty

One-year parts and workmanship, excluding labor.

Dimensions

5.25" tall, 30" long, 5.25" wide

Shipping weight

Approx. 5 lbs.

Modular Cone Dispensers

MSCONED-001

Small Cone Dispenser – 2-7/8" dia. opening

MLCONED-001

Large Cone Dispenser – 3-3/8" dia. opening

The Cone Dispensers front plate is equipped with a latch to keep the drawer closed. It also has 2 safety catches to prevent the drawer from accidentally sliding out. These dispensers can be attached to other Cone Dispensers or Cup Dispensers (MCUPD-001).

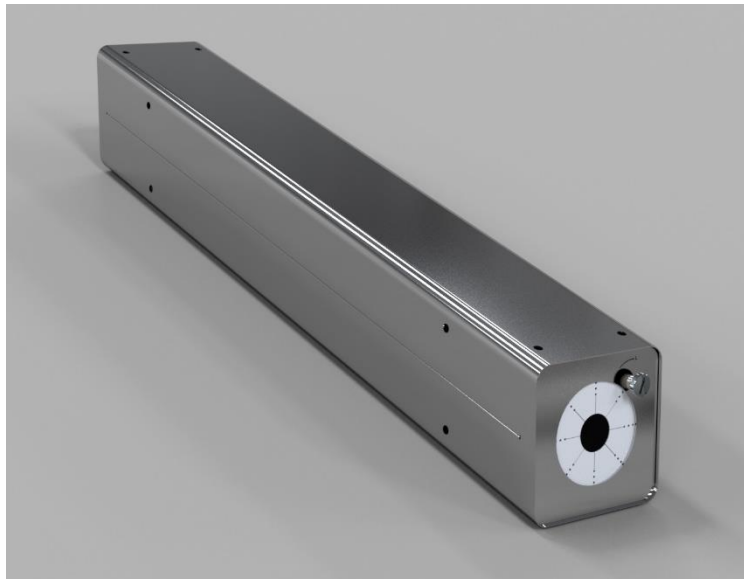

Included

Modular Cone Drawer
Hardware to attach to another modular cone or cup unit.
1 baffle (fits both size drawers)

Spare Parts

Baffle (fits both size drawers)
P/N 140-005
Turn Latch
P/N 49-2

Warranty

One-year parts and workmanship, excluding labor.

Dimensions

5.25" tall, 30" long, 5.25" wide

Shipping weight

Approx. 11 lbs.

Modular Mounting Bracket

MMB16-001P

Mounting Bracket for 16" wide freezer

MMB26-001P

Mounting Bracket for 26" wide freezer

The mounting brackets are fabricated with perforated sides, designed to improve air flow on top of the freezer. The 16" mounting bracket supports arrays 3 to 5 units wide. It will work on freezers 13-1/4" to 19-1/2" wide. The 26" mounting bracket supports arrays 5 to 6 units wide. It will work on freezers 23-1/4" to 29-1/2" wide.

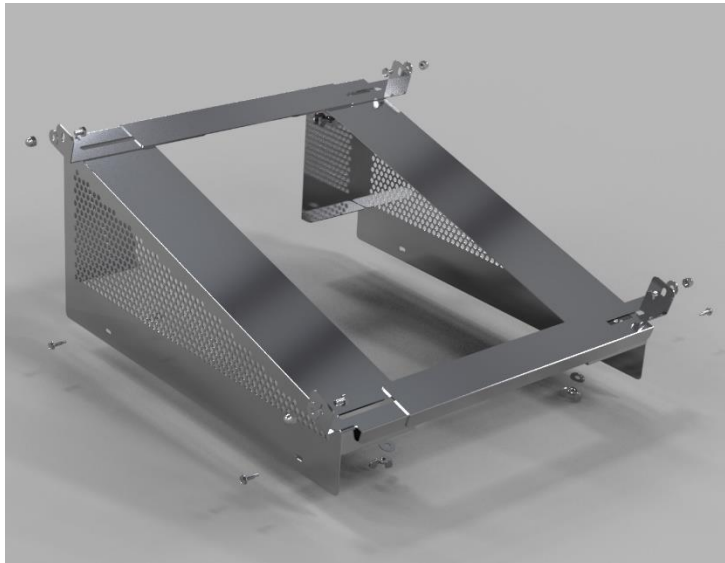

Warranty

One-year parts and workmanship, excluding labor.

Material

430 Stainless Steel

Included

Bracket

Hardware to attach to freezer & dispensers

Shipping weight

Approx. 3 lb.

Modular Side Mount Bracket

MSMB-001L

Left Side Modular Bracket

MSMB-001R

Right Side Modular Bracket

The Modular Side Mount Bracket works with the Modular Cone and Cup Dispensers (MCUPD-001, MLCONED-001 & MSCONED-001). The intent of this bracket is to mount dispensing equipment to the side of your freezer. MSMB-001R mounts to the right side of freezer and MSMB-001L mounts to the left. The below pictures show the bracket with one cone dispenser and then with one cone and two cup dispensers. You can mount as many as 5 pieces of dispensing equipment to this bracket. Each unit comes with hardware to mount to freezer and to mount to one piece of dispensing equipment. They also come with two gray bump-ons to compensate for the offset.



Warranty

One-year parts and workmanship, excluding labor.

Dimensions

22" long, 8" wide with slight offset

Material

430 Stainless Steel

Included

Bracket

Hardware to attach to freezer & dispenser

Two bump-ons

Shipping weight

Approx. 1 lb.

Printer Holding Tray

PHT-001

The Printer Holding Tray is designed to hold the printer used to print order identification labels in the treat department.

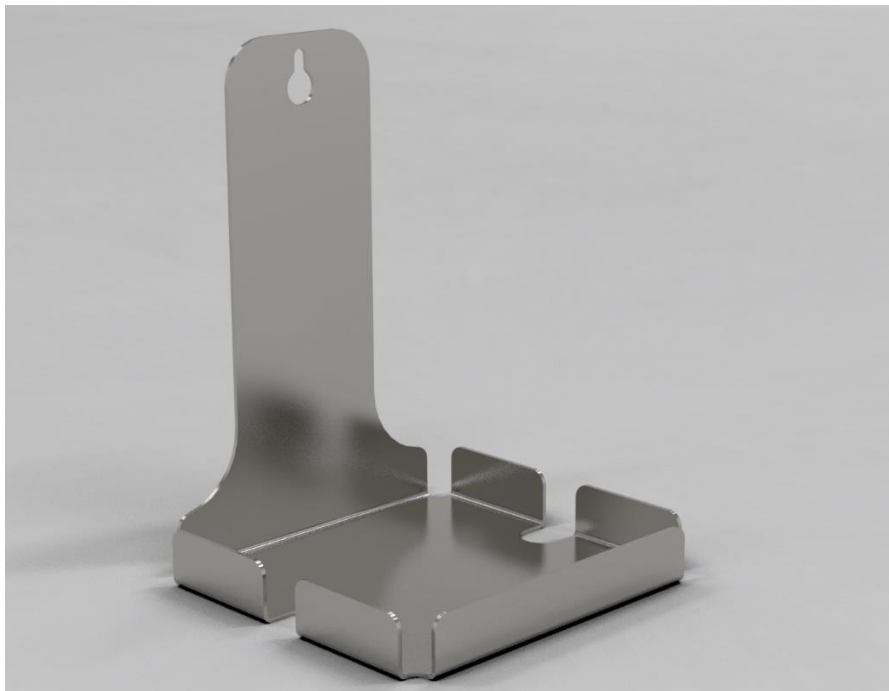

Warranty

One-year parts and workmanship, excluding labor.

Dimensions

8-1/2" high x 6.25" wide x 6" deep

Material

304 Stainless Steel

Included

1" x 2" 3M VMB Tape Patch

Shipping weight

Approx. 3 lbs.

Cake Forms & Cake Comb

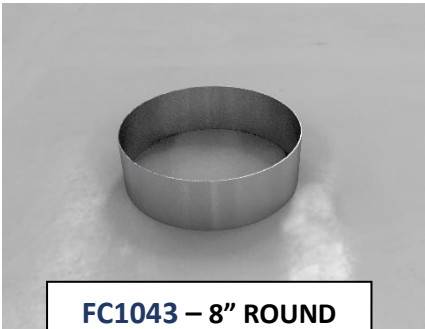

FC1043 – 8" ROUND
8" dia x 2.5" tall

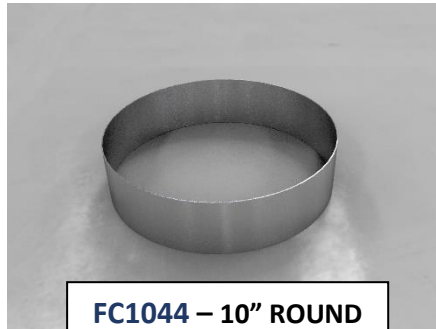

FC1044 – 10" ROUND
10" dia x 2.5" tall Steel



FC2006 – 6" ROUND
6" dia x 2" tall

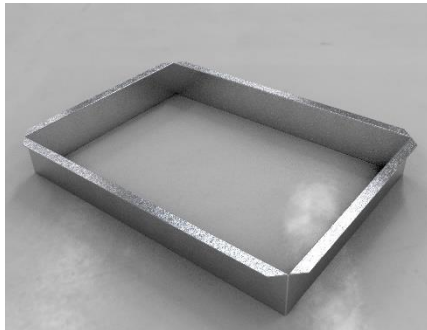

FC1045 – RECTANGULAR
14.125" x 10" x 2.5" tall



CC22G – CAKE COMB
4.1" x 3.2" x .030 thick



FC1242 – 2" TALL HEART SHAPED "SWEETHEART"
6.25" wide x 2" tall

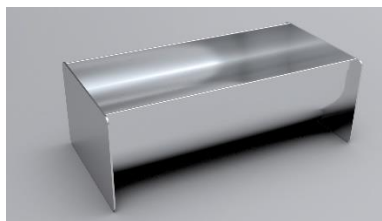

LRCF-002 – LOG ROLL CAKE FORM
9.375" length x 3" deep x 4.8" wide

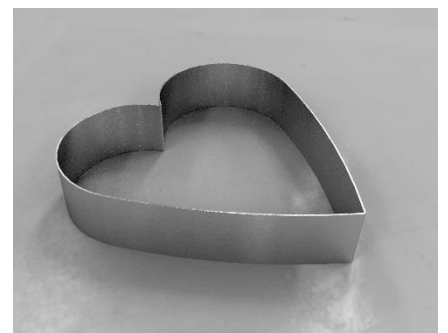

FC1046 – LARGE HEART SHAPED
9.5" wide x 2.5" tall

Warranty

One-year parts and workmanship, excluding labor.

Material

304 Stainless Steel

Shipping weight

Cake Forms – approx. 1-2 lbs/ea

Cake Comb – approx. .1 lb/ea

3" round Dilly Bar Mold

DBM-3ROUND

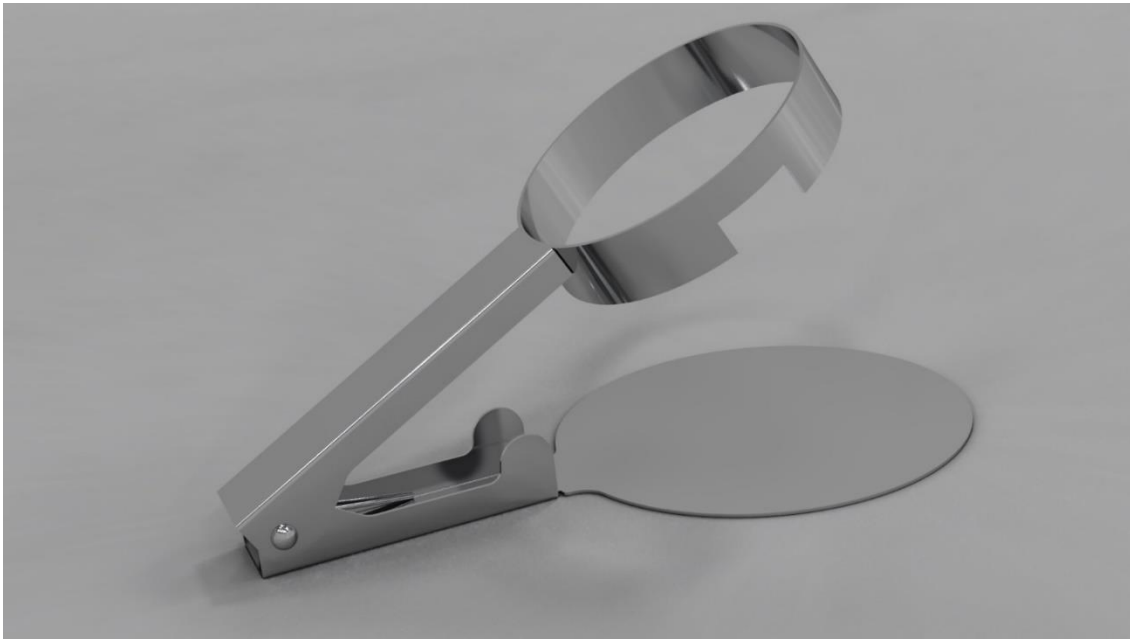

Warranty

One-year parts and workmanship, excluding labor.

Dimensions

8" length x 4" wide x 3/4" height

Material

304 Stainless Steel

Included

Dilly Bar Mold

Shipping weight

Approx. 1/2 lbs.

Cone Holders

The 1HCH & 5 HCH are both constructed using 304 stainless steel; the 5HCH uses 18 gauge and the 1HCH uses 20 gauge. Both models are fully deburred.

1HCH

One-hole cone holder



5HCH

Five-hole cone holder



Warranty

One-year parts and workmanship, excluding labor.

Dimensions

1HCH is 4" tall x 4-1/2" wide x 3" deep with one 1-1/2" diameter hole.

5HCH is 4" tall x 9" wide x 6" deep with five 1-1/2" diameter holes.

Included

Cone holder

Shipping weight

Approx. 1 lb.

Fudge Pump Stands

These stands are designed to allow for more room while operating the fudge pump. Each stand comes with rubber feet to prevent the stand from sliding around.

205

2.5" tall Fudge Pump Stand



500

5" tall Fudge Pump Stand



Warranty

One-year parts and workmanship, excluding labor.

Dimensions

PN 205: 2-1/2" tall, 6-1/4" wide and 6-1/4" deep.

PN 500: 5" tall, 6-1/4" wide and 6-1/4" deep.

Material

304 Stainless Steel

Included

Fudge pump stand

Rubber feet

Shipping weight

Approx. 3 lbs.

Server Jar Rack

SJR-004

This tabletop rack can hold up to 4 server jars. These jars do not come with the unit and are not available through Seelye Craftsmen Co. Please see your distributor for more information.



Warranty

One-year parts and workmanship, excluding labor.

Dimensions

18.2" long x 6.5" tall x 6.5" wide

Material

304 Stainless Steel

Included

Server Jar Rack

(4) rubber feet

Shipping weight

Approx. 3.5 lbs.

Server Jar Racks

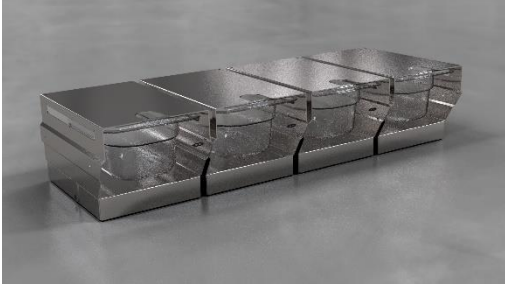

SJR-006-4W
18.4" length x 3.8" height x 7" deep



SJR-006-2x2
9.2" length x 6.75" height x 7" deep

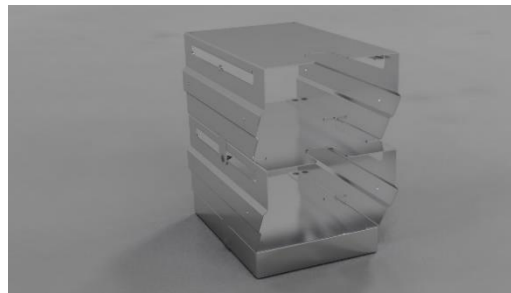

SJR-006
4.6" length x 6.75" tall x 7" deep

Warranty

One-year parts and workmanship, excluding labor.

Specifications

All units come assembled with stainless steel hardware – plastic trays not included.

Shipping weight

SJR-006-4W – 6 lbs

SJR-006-2x2 - 5 lbs

SJR-006 – 2.5 lbs

Stand Off Brace

290797

9" Standoff Brace for 4 bank blizzard dispensers

290798

9" Standoff Brace for 2 bank blizzard dispensers

The Standoff brace is used with the Blizzard Dispenser Brackets. The bracket mounts to the stand off brace, then the blizzard treat dispensers are mounted to the blizzard dispenser bracket.



Warranty

One-year parts and workmanship, excluding labor.

Included

Bracket

Hardware; nuts and screws

Material

304 Stainless Steel

Shipping weight

290797 - Approx. 13 lbs.

290798 – Approx. 10 lbs.

3 Hole Cover

3HC-001

The 3 Hole Cover slides onto a 1/3 size pan. (Pan not included.) Constructed of 304 stainless steel.

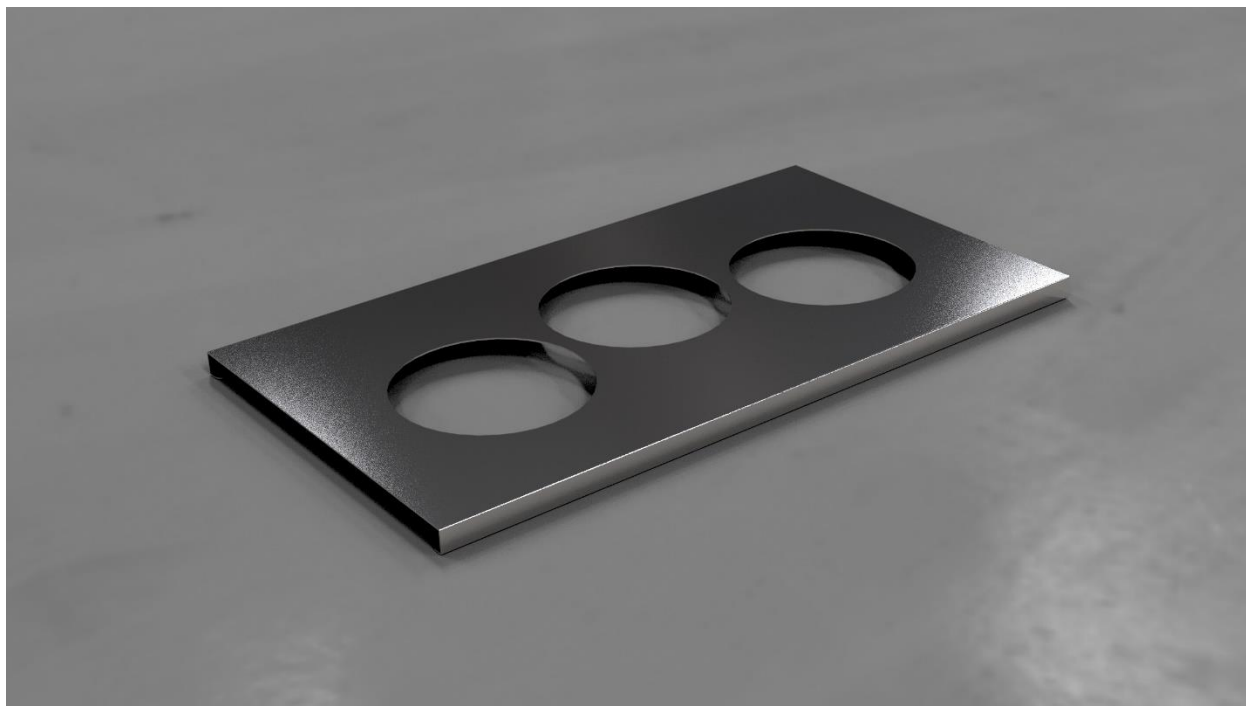

Warranty

One-year parts and workmanship, excluding labor.

Dimensions

12-7/8" length x 7" wide x .420" height

Material

304 Stainless Steel

Included

3 Hole Cover

Shipping weight

Approx. 1 lbs.

Drink Lid Holder

460-009

The drink lid holder can be mounted to the counter facing or a vertical wall surface. The three compartments are suitable for a variety of different lid sizes. This unit is specifically designed for the Dairy Queen system.

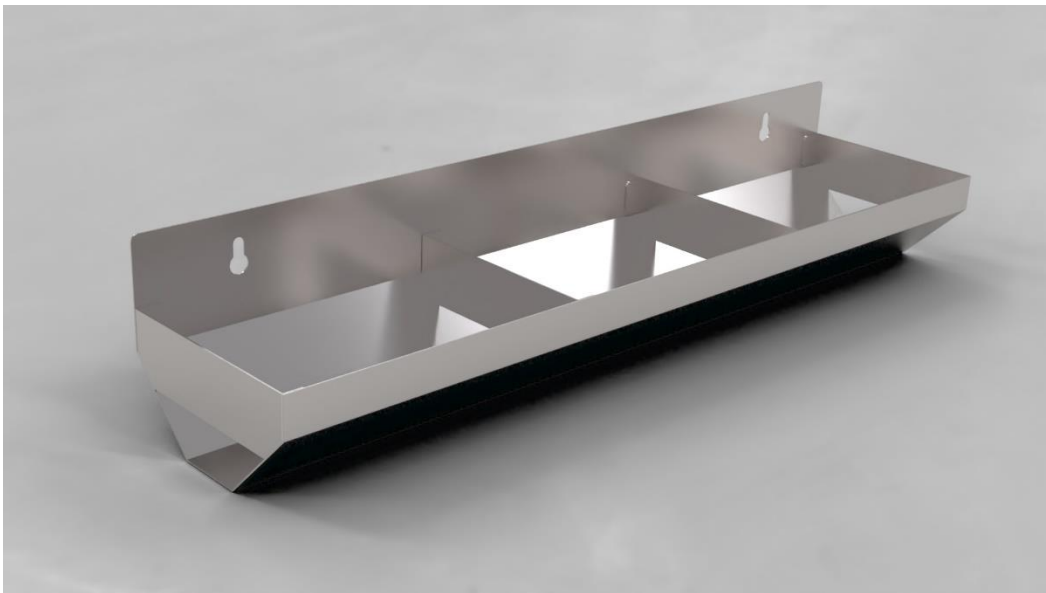

Warranty

One-year parts and workmanship, excluding labor.

Dimensions

3-1/2" high x 18" wide x 4-1/4" deep

Material

304 Stainless Steel

Included

Drink lid holder

***Mounting hardware not included*

Shipping weight

Approx. 4 lbs.

Parchment Paper Holder (w/ mtg brkt)

PPHC-001

The Parchment Paper Holder includes a stainless steel paper case (2pcs) and a mounting bracket.



Warranty

One-year parts and workmanship, excluding labor.

Dimensions

Paper holder—12.9" x 8.9" x 1.1" tall assembled

Mounting Bracket—3" tall x 8" x 9"

Material

304 Stainless Steel

Included

Paper Holder (2 pcs)

Mounting Bracket

(4) rubber feet

Shipping weight

Approx. 4 lbs.

Paper Collar Holder

132-017

Each unit is equipped with 2 mounting holes. Hardware not included.



Warranty

One-year parts and workmanship, excluding labor.

Dimensions

14" long

Base: 4-1/2" x 4-1/2" w/ a 1-1/4" lip

Material

304 Stainless Steel

Included

Paper Collar Holder

***Mounting hardware not included*

Shipping weight

Approx. 1 lbs.

1 Prong Paper Collar Holder

1PCH-01

This item is fabricated using 304 Stainless Steel. It is designed to rest on top of the soft serve freezer, along its side.

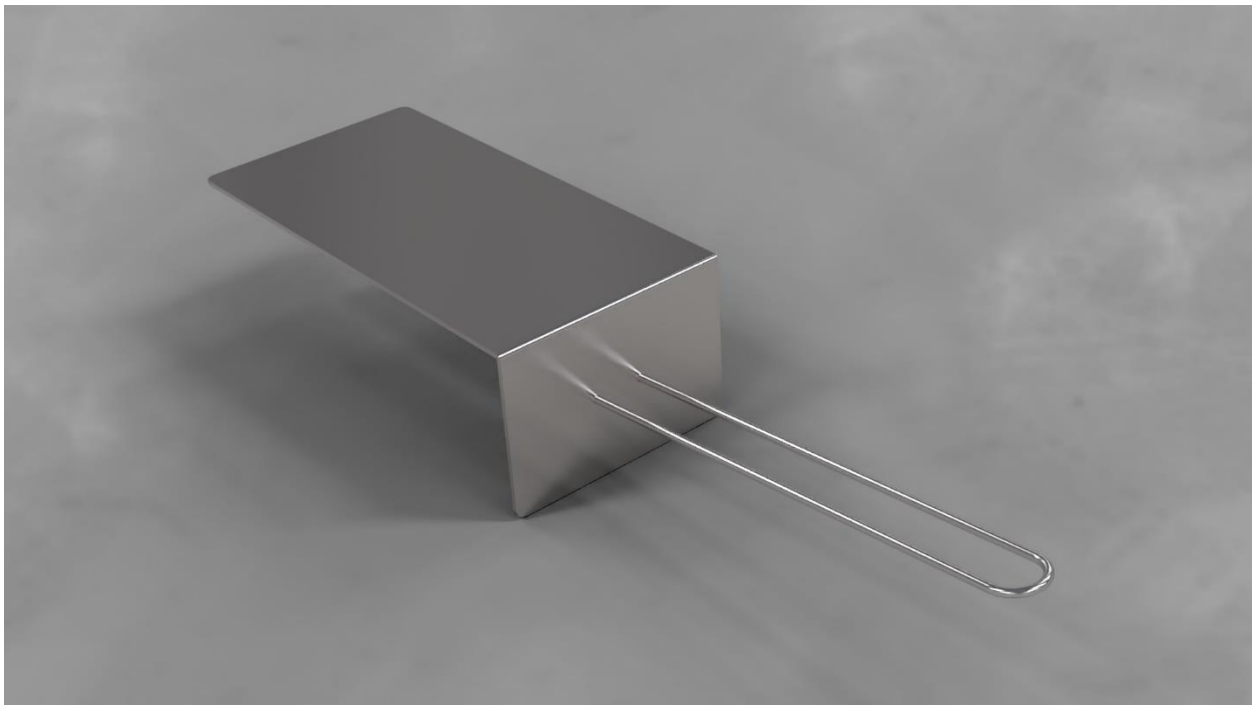

Warranty

One-year parts and workmanship, excluding labor.

Dimensions

2" high x 3" wide x 12" deep

Material

304 Stainless Steel

Included

1 prong holder

Shipping weight

Approx. 1/2 lbs.

4 Prong Paper Collar Holder

4PCH-01

This item is fabricated using 304 Stainless Steel. It is designed to rest on top of the soft serve freezer, along its side.

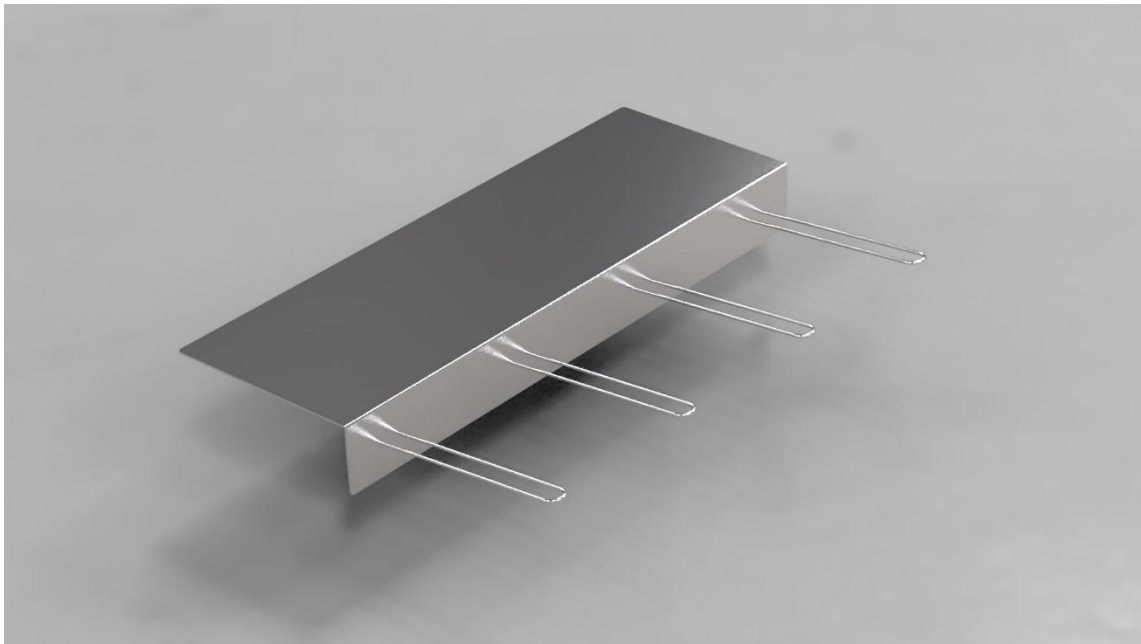

Warranty

One-year parts and workmanship, excluding labor.

Dimensions

18" long x 6" deep; each prong is 5-1/2" long

Included

4 prong paper collar holder

Shipping weight

Approx. 3 lbs.

Drop-in Sink with Faucet Assembly

132-013

The Drop-in Sink is designed to drop into a countertop and be held in place with nuts and (4) 2.5" studs welded to the unit. Each unit comes with a 1/3 size 6" deep stainless pan welded into the unit.



Replacement Parts

Cold water faucet
K20-8030

Overflow tube
E12-0220-SP

Warranty

One-year parts and workmanship, excluding labor.

Dimensions

8" wide x 16" long

Included

Sink

Faucet

Overflow tube

Sink drain

Required hardware

***No plumbing or piping is included*

Shipping weight

Approx. 8 lbs.

Add on Cup Dispenser

141-302SC

Used to add more cup dispensing capacity to the Cone/Cup Dispenser (141301A, 141301B & 141301C). This unit is attached to an existing Cone/Cup Dispenser using a bolt and wingnut.



***While still available to order, the Side Mount Cup Dispenser has been replaced by the Modular Cone & Cup Equipment. Using a Modular Side Mount Bracket one can mount Modular Cup Dispensers or Modular Cone Dispensers. ***

Warranty

One-year parts and workmanship, excluding labor.

Dimensions

5-1/4" wide x 13-1/2" high x 23-3/4" deep

Shipping weight

Approx. 15 lbs.

Cone Drawers

141-306

3 Hole Cone Drawer

141-307

4 Hole Cone Drawer

The 141-306 and 141-307 (shown) are drawers designed as spare parts for the 141301A Cone Cabinet. The 3 holes drawer is for large cones and the 4 hole accommodates small cones. Each drawer is equipped with a safety bracket to help keep the drawer from sliding out of the cabinet on its own.

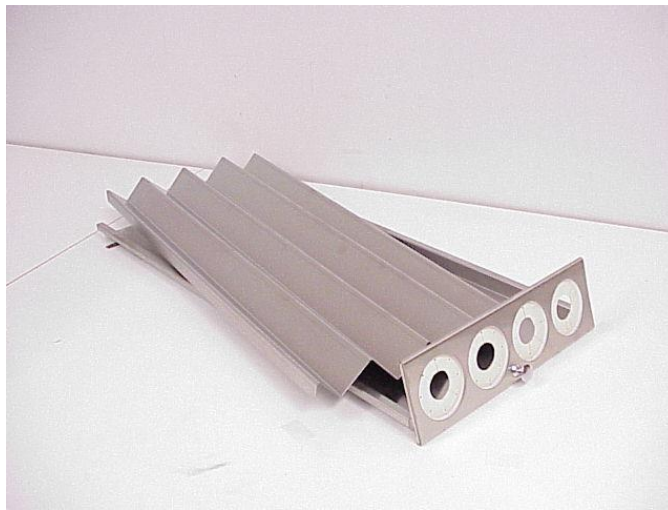

Warranty

One-year parts and workmanship, excluding labor.

Included

Drawer

Baffle

Cone Separator

Drawer Knob

Material

304 Stainless Steel

Shipping weight

Approx. 13 lbs.